

## Bulletin 3000: Line Support Blocks



### Introduction

The Tube Support Block, which is also identified as a Block clamp, Tube support or Fairlead Block, is by necessity a custom designed part. It is one of the original clamping designs used as far back as pre WWII. In those days the designs were manufactured from hardwood, which later progressed to phenolic and on to cork and neoprene. During the 1960's in an effort to conserve weight and space their use diminished, however, with the advent of redesigned heavy duty hydraulic systems in the larger aircraft, such as the 747 and the vibration problems experienced in helicopters, their use was again required, but their need in this resurgence was for a different reason than the original use which necessitated new materials. Since their original conception, aircraft have increased in size and weight requiring larger and reduced hydraulic systems which created vibration and surge problems plus new requirements for better performance in the presence of fire, fluid and corrosion resistance conditions. These conditions ruled out the use of the original materials mentioned above and brought into use a new family of elastomers specifically designed for the application and environment. TA was the leader in this effort which not only involved new materials, but also new concepts and applications. All of these will be described, and commented upon in this Engineering Document.

## Design

The basic design of any Line Support Block will vary from application to application due to tube size, required spacing and location. In addition, environment and available mounting area will dictate various requirements. First let us become familiar with the basic nomenclature and minimum dimensions. (See Exhibit I below)

## Dimensioning

The minimum and maximum dimensional recommendations shown are an average for various materials, configurations and manufacturing methods. Many aspects of the design criteria will alter the dimensions and tolerances to varying degrees. For instance, soft elastomers, require a broader tolerance range than harder ones.

In addition, the method of manufacture has a very direct affect on tolerances, and cost. This makes it essential to provide some reasonable indication of quantity at the time of conception in order that the best and most economical method is considered.

The TA Engineering Department is available to assist in determining the best and most economical approach, and provide design proof samples for your "Fit and Function" verification.

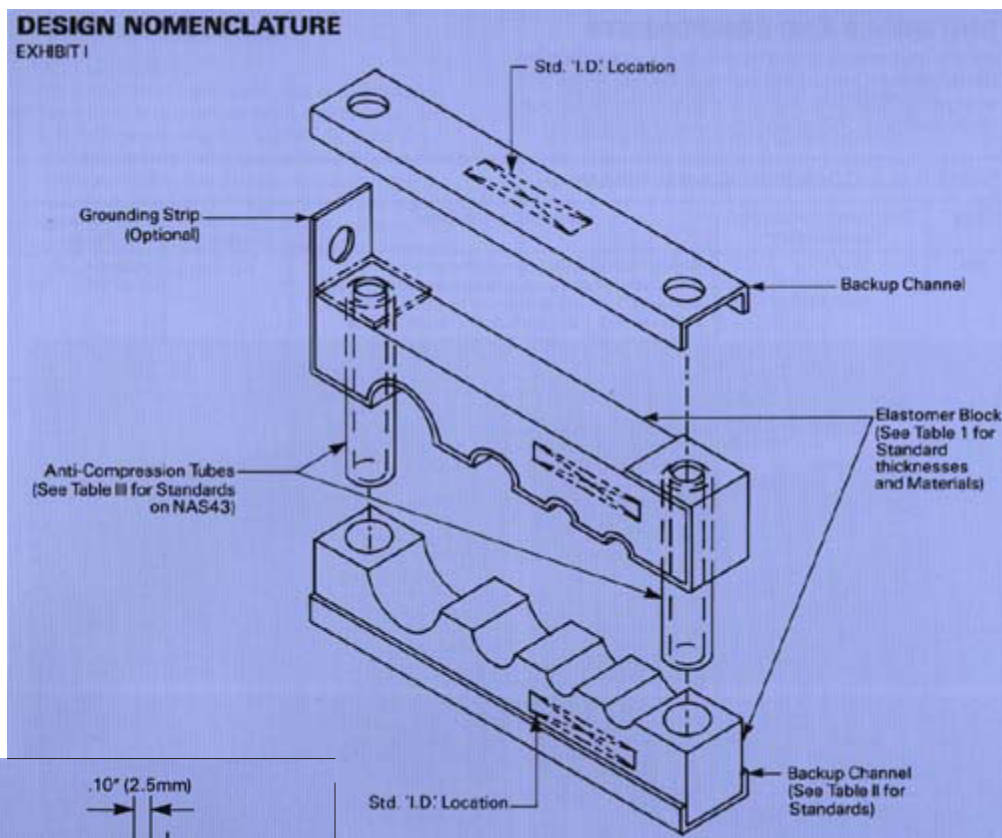

## Dimensions

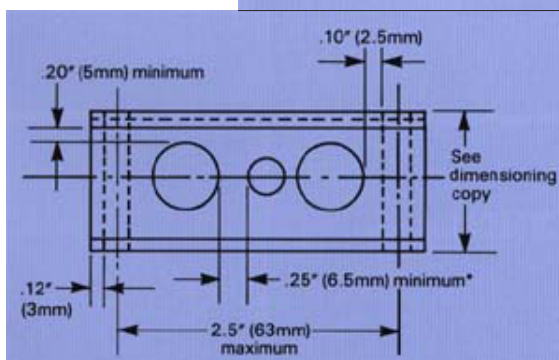

\*Consult MIL-H-5440 for minimum tube spacing for hydraulic systems

### Materials and Components

As you have already noted from Exhibit I, a Line Support Block is a multi-component clamping device. For an economical approach, we have standardized on various components and materials. These are charted below:

Table I: Elastomer Block Materials

Code	Compound No. and/or Specification	General Design Data	Hardness Durometer	Temperature Range
NB	TA77-2A M85052/1 M64559/1/	A tough buna N or Nitrile butadiene elastomer developed for clamp specifications M85052/1 and M85449/1. Its use in hydrocarbon contaminated areas on the B1-B aircraft and other aircraft has proven its performance. If a softer version is needed see Bulletin 120, TA9977, Code NH,55 durometer.	70 +/- 5	-65°F +275°F
EP	TA79-1A M85052/2 M85449/2/	An Ethylene Propylene Compound, also developed for Specification M85052 and M85449. Its primary use is in Commercial Aircraft in areas contaminated with Phosphate Ester Hydraulic Fluids. For a softer version use TA1231, Code ES, 55 durometer.	70 +/- 5	-65°F +275°F
HU	TA8827	A silicone Elastomer designed for pressurized cabin environment where fire resistance, low smoke density and toxicity are required. Resistant to Phosphate Ester Hydraulic Fluids. For a softer version use TA6711, Code HA, 55 durometer.	70 +/- 5	-65°F (-54°C) +275°F (204°C)
WH	TA7110	A high strength, high modulus Silicone Elastomer especially designed for high temperature, high vibration areas. Its excellent fluid resistance makes it outstanding for mounting Commercial Aircraft engines Hydraulic systems. If a soft material is desired, Code WD, Compound No. 9798, 60 durometer should be considered.	70 +/- 5	-65°F (-54°C) +500°F (260°C)

Additional data on the above compounds can be found in Bulletin 120 or request a copy of the specification from your TA Representative.

Note: Standard block thicknesses are 3/8", 1/2", 5/8", & 3/4".

Table II: Back-up Channel

	TA Reference Number	Dimensions			Material
		A	B	C	
	TA 1800-1	3/8	13/64	0.045	6061-T6 Aluminum
	TA 1800-2	1/2	13/64	0.045	6061-T6 Aluminum
	TA 1802	3/8	1/8	0.040	6063-T5 Aluminum
	TA 1802-1	1/2	1/8	0.040	6063-T5 Aluminum
	TA 1803	5/8	1/4	0.060	6061-T6511 Aluminum
	TA 1803-1	3/4	1/4	0.060	6061-T6511 Aluminum
	TA 1805-01	3/8	13/64	0.040	321 Stainless Steel
	TA 1805-02	1/2	13/64	0.040	321 Stainless Steel
	TA 1805-03	5/8	13/64	0.040	321 Stainless Steel
	TA 1805-04	3/4	13/64	0.040	321 Stainless Steel

Table III: Anti-Compression Tubes

TA Reference Number	I.D.	O.D.	Materials	Bolt Size
TA 1806-01	13/64	1/4	304 Stainless Steel or 6061-T6 Aluminum	10
TA 1806-05	7/32	5/16	304 Stainless Steel or 6061-T6 Aluminum	5mm
TA 1806-07	9/32	3/8	304 Stainless Steel or 6061-T6 Aluminum	1/4

Note: Other special sizes or NAS43 spacers available upon request. Please consult your TA Representative.

## Configurations

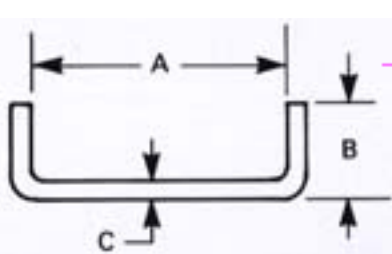
### Style TA3010

A conventional style block, less any hardware designed for tube or electrical applications. Very often these are used as “stuffer” or “fillers” to provide support and/or prevent chaffing where the tubes or wiring pass through structure. They are usually retained by the structure, or other means provided by the manufacturer of the airframe. Very popular and a proven method mounting hydraulic lines on landing gear.



### Style TA3030

A conventional style split block, including anticompression tubes and one back-up channel. These are used when mounting against flat structure or bracketry in locations where vibration or surges do not necessitate the use of 2 channel.

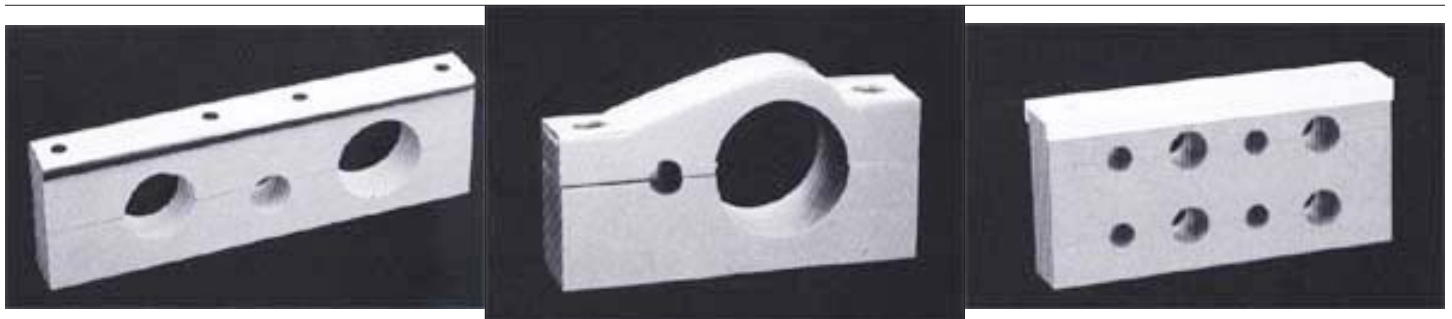

## Style TA3050

The standard configuration with a full hardware complement, as shown in Exhibit 1. The photos below exhibit a split block, however this style block as well as other configurations can also utilize slits instead of splitting into multiples. This has become increasingly popular as it preserves the one piece integrity of the block; eliminates identification problems and the possibility of lost pieces which could result in FOD damage.



## Style TA3070

This style block employs the use of clamp hardware, in most cases due to the dictates of the mounting. Many utilize the Flip Loc concept of the hinge and quick release fastener which is becoming increasingly popular. This is a result of both military and airline requirements for faster and easier maintenance as well as a reduction of loose hardware which can result in FOD damage.



## Style TA3090

This is really not a style, as it can involve any of the foregoing configurations, but a Drawing classification for those parts specified by a customer source or specification control drawing. By using the TA3095 as part of the part number, it indicates to our personnel, a specific method of identification per DOD-STD-100 (MIL-STD-130) and more important the fact that no revisions can be made except by customer request and/or with their approval.

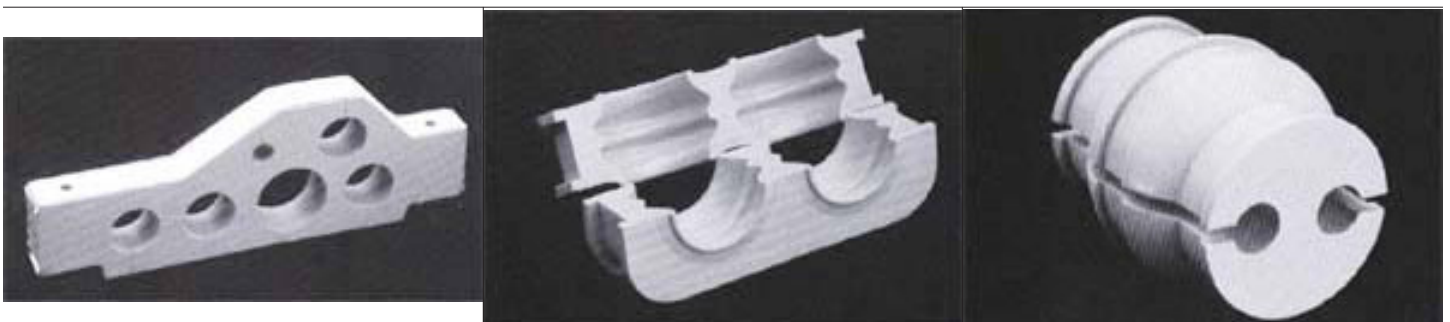

Style TA3095

This is really not a style, as it can involve any of the foregoing configurations, but a Drawing classification for those parts specified by a customer source or specification control drawing. By using the TA3095 as part of the part number, it indicates to our personnel, a specific method of identification per DOD-STD-100 (MIL-STD-130) and more important the fact that no revisions can be made except by customer request and/or with their approval.



This document is the property of Kirkhill-TA and is conveyed with the express condition that it and the information contained in it are not to be used, disclosed or reproduced in whole or in part, for any purpose without the express written consent of Kirkhill-TA; and that no right is granted to disclose or so use any information contained in said document. These restrictions do not apply to vendor proprietary parts.