

NMC

NMC CL 141N- (Series)

SUPPORT CLAMPS



Wire Management Support Clamps

Applications include holding wires, tubing, pipe conduit and wire harnesses. Advantages of this support clamp include: continuous circular support, lightweight, vibration resistance, strong and durable, non-corrosive, weather-proof, fungus-proof and resistant to most chemicals; firm base provides excellent stability even under extreme vibration, tongue and groove design prevents wire strands from being wedged between clamp feet; and inner ribs provide positive gripping.

NMC has full engineering specifications available for all items shown here. Contact us for further information.



Nylon Molding Corporation / Div. of NMC Group, Inc.

2755 Thompson Creek Road • Pomona, CA 91767-1861

800.321-1243 • 909.451-2290 • Fax: 909.593-8309

e-mail: info@nmcgroup.com • www.nmcgroup.com

NMC

NMC CL 141N- (Series)

SUPPORT CLAMPS

MATERIAL:

Nylon:

Nylon 6/6 Heat Stabilized per ASTM D4066 (PA 0121)

(For applications to 275°F)

COLOR:

Natural

SIZES:

See chart and figures below

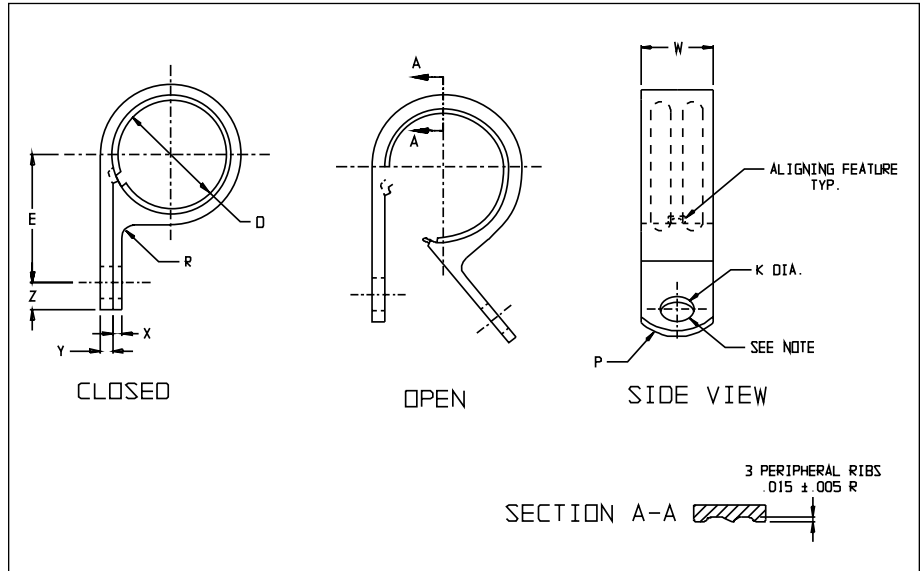

PART NO.	APPROX. CABLE BUNDLE DIA.	DIMENSIONS								
		D	E	K	P	R	W	X	Y	Z
CL141N	±1/64	±.020	±.025	±.005		±.006				
-2	1/8	.125	.420							
-3	3/16	.188	.450							
-4	1/4	.250	.485							
-5	5/16	.312	.515							
-6	3/8	.375	.545			.062				
-7	7/16	.438	.575							
-8	1/2	.500	.605							
-9	9/16	.562	.640							
-10	5/8	.625	.670					.065	.090	
-11	11/16	.688	.750							
-12	3/4	.750	.780							
-13	13/16	.812	.810							
-14	7/8	.875	.845							
-15	15/16	.938	.875							
-16	1	1.000	.910							
-17	1-1/16	1.063	.930	.203	.375		.500			.255
-18	1-1/8	1.125	.950							
-19	1-3/16	1.188	1.000							
-20	1-1/4	1.250	1.040			.109				
-22	1-3/8	1.375	1.110							
-24	1-1/2	1.500	1.170							
-26	1-5/8	1.625	1.250					.090	.125	
-28	1-3/4	1.750	1.300							
-30	1-7/8	1.875	1.355							
-32	2	2.000	1.420							

For more information call toll free: (800) 321-1243