

## JETFIRE DARMATT™ FLEXIBLE PASSIVE FIRE PROTECTION



Darchem Thermal Protection's Jetfire Darmatt™ flexible jacket Passive Fire Protection system is a high performance solution designed to meet the most demanding requirements for protection of critical flow and process equipments from Jet Fire conditions. Offering up to an unprecedented 180 minutes fire protection, JetFire Darmatt™ is the latest development of the Darmatt™ PFP system, which has been supplied extensively worldwide for both Onshore and Offshore Oil & Gas and Petrochemical installations.

### Design Specification

- **Fire Condition - Hydrocarbon Engulfment / Jet Fires up to 180 mins**
- **Blast Protection - Up to 1.62 bar**
- **Limiting Temperatures – as per project requirements, with Lloyds approved Offtranp software calculations to be issued to clients for each item of equipment protected.**

### Construction Details

Each Jetfire Darmatt™ PFP system is specifically engineered to fit closely around the protected equipment providing a removable, compact and user friendly enclosure. The system is constructed from pre-shaped panels designed to fit together around the equipment to be protected.

Each panel is constructed from layers of insulation fibre and reflective foil, compressed and studded with nylon pins throughout the panel's area. The blanket is shrouded on the hot face by a steel mesh and the complete exterior covered by a non-fire rated weather resistant skin.

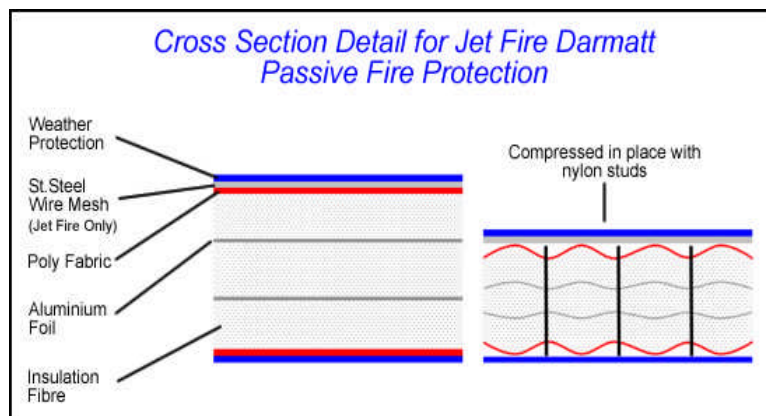

The nylon pins hold the components in the Darmatt™ PFP system together to ensure that the insulation materials remain securely in place and do not migrate to a different part of the panel (as experienced with lower quality insulation jacket systems). The nylon pins also compress the insulation to approximately 60% of its original thickness to provide a very flexible but compact system. All this helps to ensure that the PFP system is easy to remove and install again.

## Inspection Hatches and Penetrations

Inspection hatches can be provided for each Jetfire Darmatt™ installation to provide quick access to areas that require regular inspection or maintenance. Lloyds have approved these hatches for use with the Jetfire Darmatt™ system.

Penetrations for operating mechanisms, hydraulic tubing and position indicators etc. can be provided to facilitate problem-free operation and maintenance of equipment without the need to remove the jackets. It is important that the client identifies any requirements for hatches and penetrations as early as possible such that they can be incorporated into the PFP system's design.

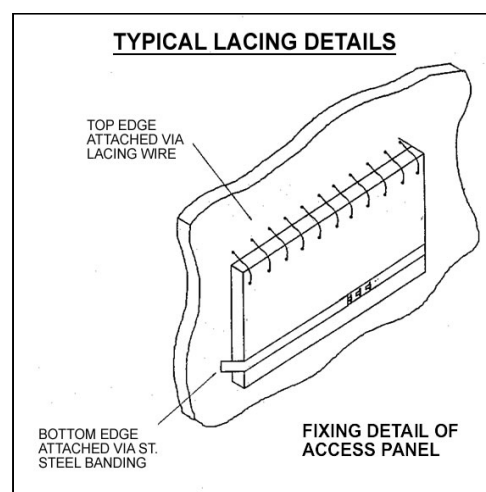

## Jetfire Darmatt™ PFP Lacing Method

The Darmatt™ PFP system is fastened together using high quality PVC coated stainless steel wire lacing. This lacing method is simple to apply and provides an extremely durable fastening, ensuring that the panels are secured permanently. By using this lacing method, the panels can be pulled tight around the equipment in such a way that they take shape around the valve/actuator. Once installed, each panel will retain its moulded shape making future removal/installation quicker and easier. This lacing method has been used on all Darmatt™ PFP systems supplied by Darchem since 1986.

## Testing & Certification



Since its introduction the Jetfire Darmatt™ PFP System has been tested continuously to prove its capability as a passive fire protection system. The system is ideally suited to protect ESD valves, actuators, pipe work, and other process equipment against hydrocarbon engulfment and Jet Fire.

Jetfire Darmatt™ has been tested and is certified to the standards ISO 22899-1 and OTI 95 634 for "Jet Fire Resistance Test of Passive Protection Materials", the latest recognised standards for Jet Fire is testing.

Jetfire Darmatt™ has also undergone independent overpressure blast tests and is certified for blast pressures up to 1.62 bar.

## Optimisation of Insulation Thickness

Darchem Engineering use Lloyds approved software called “Offtranp” to determine the optimal insulation thickness for each PFP application. This ensures that adequate insulation is provided to protect the equipment in the fire condition and that the thickness of the insulation is kept to the absolute minimum. The factors below are input into the “Offtranp” software, which calculates and displays the temperature drop across the insulation after a set period of time during the fire.

- **Type of Fire**
- **Duration of Fire**
- **Relevant ambient and operating temperatures**
- **Limiting Temperature Rise**
- **Mass and volume of Equipment**
- **Exposed Surface Area**

## Temperature Limitation

A selection of outer weather resistant clothes is available to take into account differing ambient and operating temperatures for the equipment being protected. The standard Darmatt™ PFP system has a PVC coated outer cloth suitable for a maximum operating temperature of up to 60°C. However for high process temperatures a Silicone coated outer cloth withstanding up to 700°C can be utilised.

## Product Customisation

The Jetfire Darmatt™ PFP System can be customised to meet the customers’ specific environmental requirements, these include the following:-

- **Coloured Cloth to be in line with plant identification**
- **DARVENT grilles to aid with ventilation to reduce the internal ambient temperature of protected item and prevent the build up of gas.**
- **Access Doors for maintenance or operating purposes.**
- **Custom designed Rain Jackets for added weather protection.**



Jetfire Darmatt™ applications include:



Valves, actuators, and instrumentation



Process vessels



Cable trays



Pipe work

Darchem Thermal Protection, Darchem Engineering Ltd, Stillington, Stockton-On-Tees, TS21 1LB, UK  
Tel +44 1740 630461 – Email [dtpsales@darchem.co.uk](mailto:dtpsales@darchem.co.uk) – Website [www.darchem.co.uk](http://www.darchem.co.uk)